

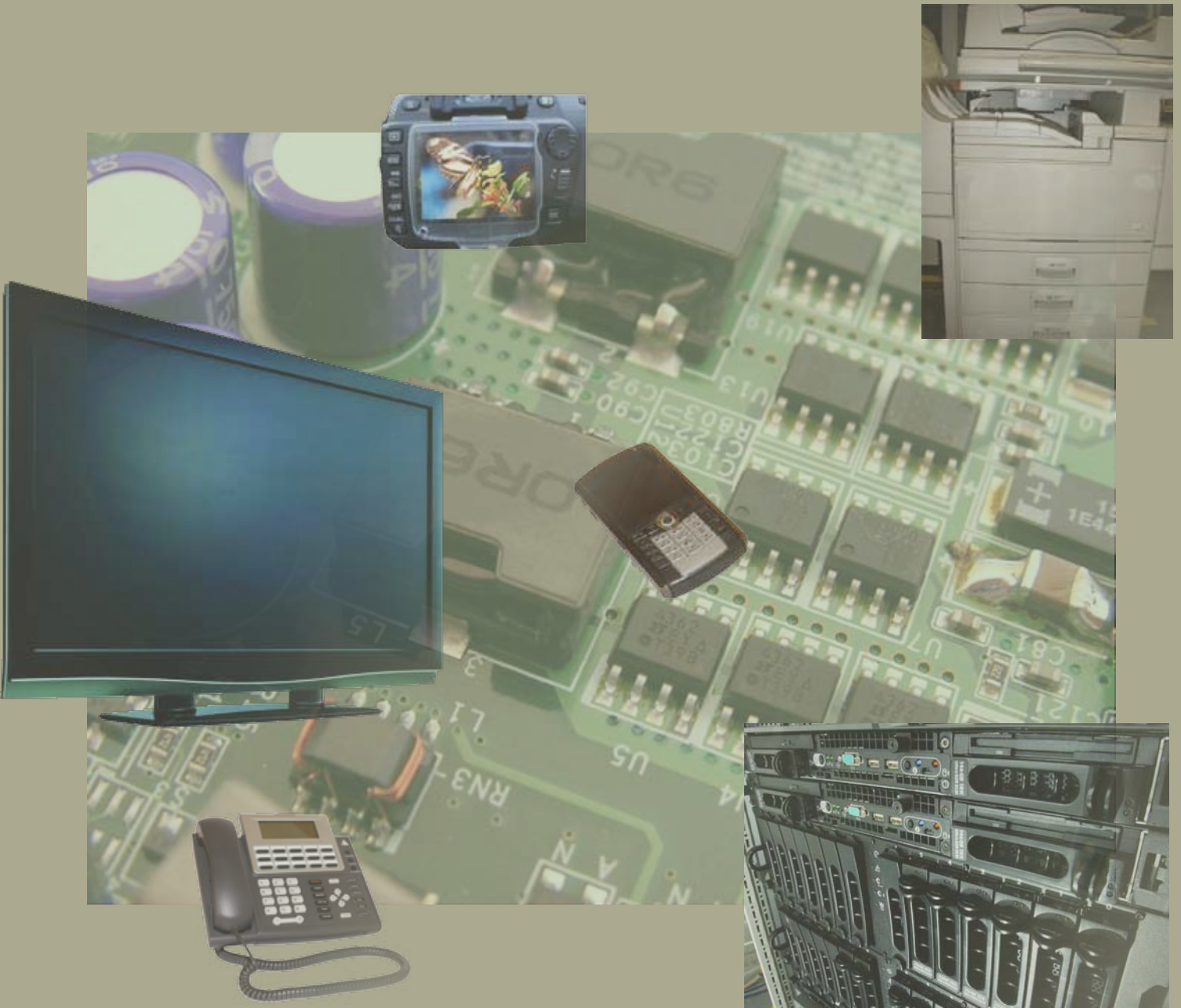

AKM Semiconductor, Inc.

Power Management Devices

Selection Guide



DC/DC Converters • Low Dropout Linear Regulators
White LED Drivers • Active Noise Filters • White LED Flash Drivers

AKM Power Management Device ICs

AKPD

AKPD is AKM's power management device division. AKM created AKPD in 2010 by combining AKM's DC/DC, Al-Aid's DC/DC and Toko Semiconductor division Analog customer focused design and manufacturing teams. This new team combines the experience and expertise of each group creating a synergy for AKPD future analog designs. AKM brings its expertise in high efficiency DC/DC converters for portable and mobile (low power small footprint) applications and system power management core designs for larger ICs. Al-Aid brings its expertise in high load step-down DC/DC converters and controllers, high performance power management ICs, and core technologies in: high efficiency during light loads, protection circuitry, and load change response performance. Toko Semiconductor division brings 17 plus years in the North American market and its expertise in step-up DC/DC white LED drivers for flash and backlighting of small to large displays, CMOS, Bipolar, and BiMOS low power LDOs for portable and mobile (low power small footprint) applications, medium to high voltage processes, and very high volume low cost manufacturing.

Table of Contents

Application Guide

Handheld Device.....	3
Portable Device.....	4
Plug-in Device.....	4

Selection Guide

DC/DC Controller/Converter.....	5
LDO.....	6
Active Noise Filter.....	8
White LED Flash Driver.....	8
Linear Constant Current LED Driver.....	8
White LED Driver.....	9

Package Guide.....	10
--------------------	----

Contacting AKM

On the web: <http://www.akm.com>

Technical support: icinfo@akm.com - access to the entire AKM applications team. If you have questions or need help with an AKM part, send an e-mail to this address and get a response within minutes.

Sales support: sales@akm.com - if you need assistance purchasing parts, getting price quotes, or requesting samples, send an e-mail to this address and a North American sales representative will contact you.

USA headquarters: 408-436-8580

Toll -free 1-888-AKM-SEMI (256-7364)

AKM Semiconductor, Inc.
1731 Technology Drive, Suite 500
San Jose, CA 95110

Product by Functions

Power Supply ICs

DC/DC Converters	Step-up and Step-down converters using an internal switching transistor and an internal or external rectifier ranging from 125mA to 3A output in packages ranging from 8 pin WL-CSP to 16 pin SSOP
DC/DC Controllers	Step-up and Step-down controllers using an external switching transistor and an external rectifier ranging from 1A to 10A output in packages ranging from 8 pin SSOP to 30 pin VSOP
LDOs	Low Dropout Regulators using Bipolar, CMOS and BiMOS processes with output voltage ranges from 1.2 to 18V & -1.3 to -17.5V in packages ranging from 4 pin WL-CSP (0.75x0.75mm) to 5 pin TO252
Noise Filters	Constant adjustable (with external components) dropout voltage active noise filters providing 65dB of ripple rejection in 5 pin SOT23 or 8 pin HSOP package

Flash Driver ICs

2 to 4 White LEDs	Step-up DC/DC flash drivers using an internal switching transistor and an external rectifier to drive 2 to 4 LEDs at 100mA in packages ranging from 9 pin WL-CSP to 8 pin SON
1 to 2 White LEDs	Step-up DC/DC flash drivers using an internal switching transistor and an external rectifier to drive 1 to 2 LEDs (series & parallel) at 725 to 1000mA in packages ranging from 9 pin WL-CSP to 16 pin UQFN

LED Drivers ICs

Small Displays	Step-up DC/DC LED drivers using an internal switching transistor and an external or internal rectifier to drive 2 to 6 LEDs in series at 15 to 30mA in packages ranging from 8 pin WL-CSP to 8 pin SON
Medium Displays	Step-up DC/DC LED drivers using an internal switching transistor and an external rectifier to drive 10 (1 channel) to 30 (3 channels) LEDs at 25 to 120mA in packages ranging from 8 pin SON to 24 pin TSSOP
Large Displays	Step-up DC/DC LED drivers using an internal switching transistor and an external rectifier to drive 60 (6 channels) to 98 (8 channels) LEDs at 26 to 40mA in a 24 pin HQFN package
Linear Constant Current	Constant current source drivers to drive 1 to 6 (parallel) LEDs in packages ranging from 4 to 12 pin WL-CSP

Application Guide

AKPD Commitment to Excellence

At AKPD quality is designed in, fabricated in, tested, verified and delivered.

This starts with our design teams. Our design teams work in an open creative environment that allows and encourages them to react quickly to customer and market feedback. They also work closely with our production and packaging teams to create customer focused, low power, minimum footprint designs. This has allowed us to be a leader in delivering WLED backlight drivers to the mobile phone market. We are constantly looking at ways to reduce the overall footprint and height, whether it is by using smaller and smaller WL-CSP or SON packages.

Our products have a history of very satisfied customers, exceptional reliability and excellent on time delivery record. We are committed to excellence and complete customer satisfaction, and we back up this commitment with ISO9001 certification, robust specifications, high production yields, 100% test and inspection, and the use of statistical quality control (SQC) in manufacturing to the 6 sigma level. We constantly review our SQC data and use this information to tweak our designs and processes to further improve our quality and yields.

AKPD devices are ideal for applications that require minimum footprint, low cost, high performance, high efficiency and exceptional reliability.

Handheld Device

For handheld devices power consumption and size are critical. AKM is a leader in miniature WL-CSP and SON packages. Also, circuit size is kept to a minimum by using internal FETs and synchronous rectification for DC/DCs and capacitorless LDO designs.

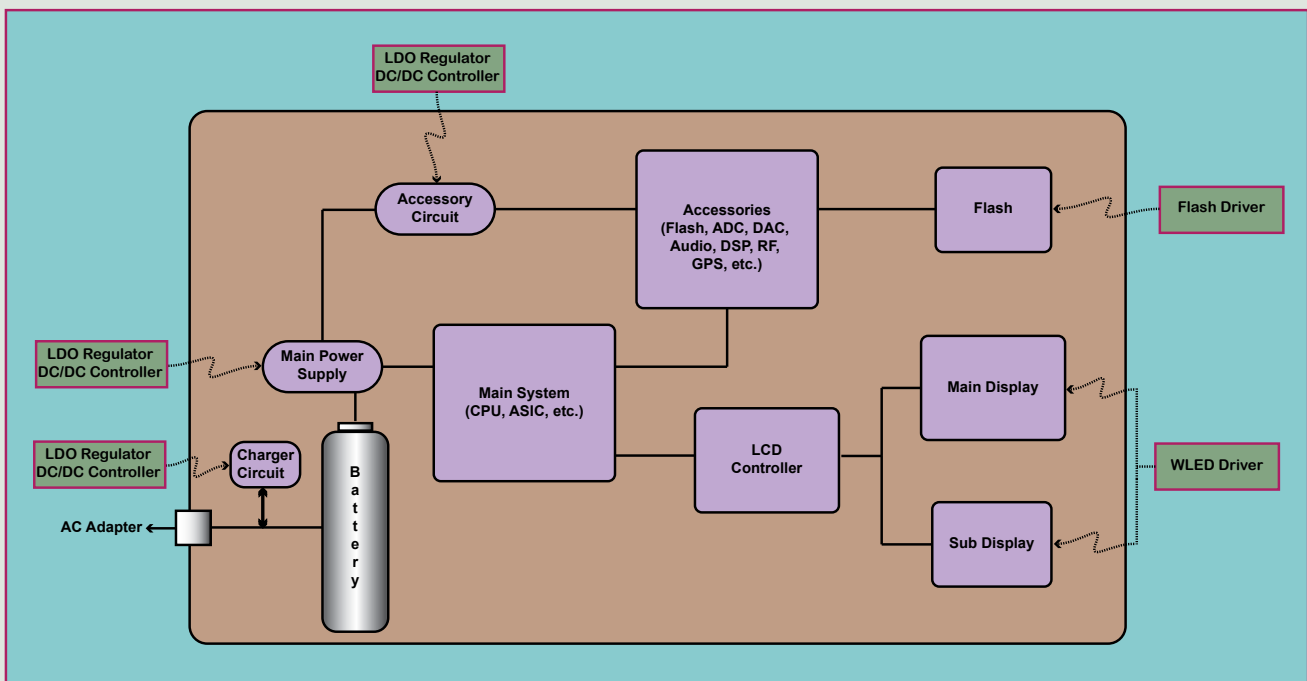

Portable Device

Power consumption remains critical for portable devices even as power output requirements increase. AKM covers these applications with small package sizes, high efficiencies, and low dropout voltages.

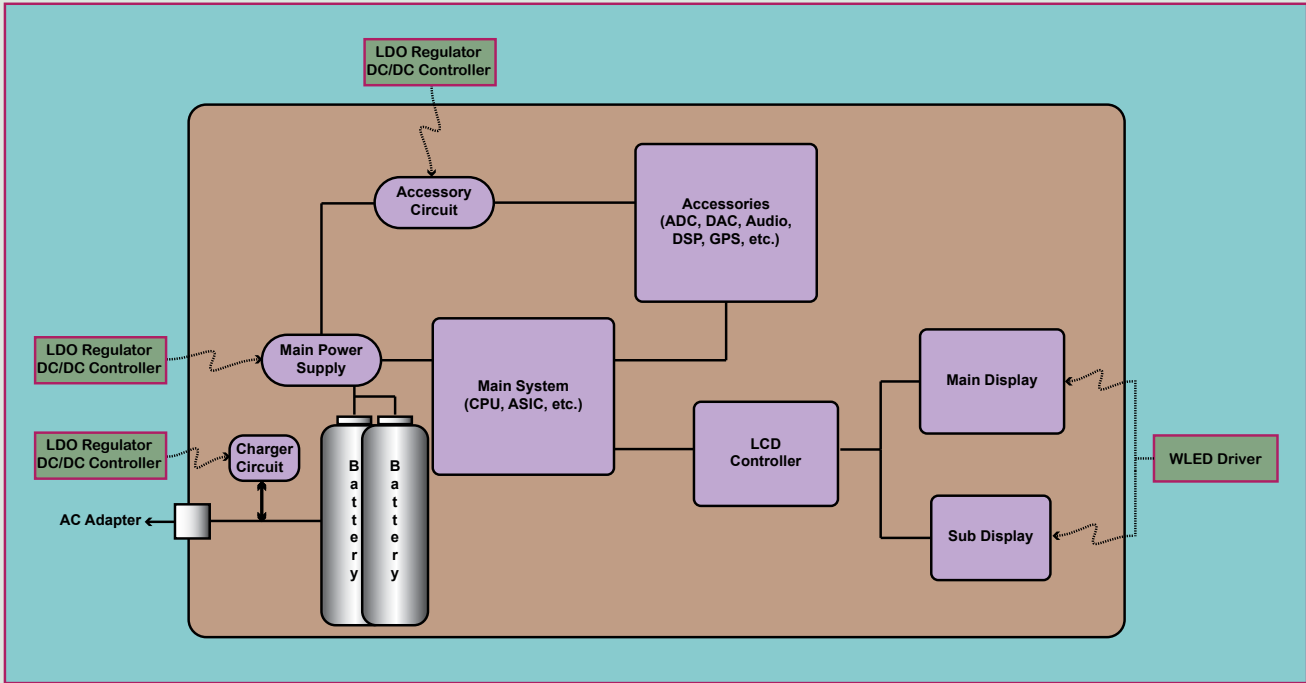

Plug-in Device

Efficiency and performance are the critical features for plug-in device applications. AKM offers high output Power Supply devices, Flash Drivers and LED Drivers with the performance you need.

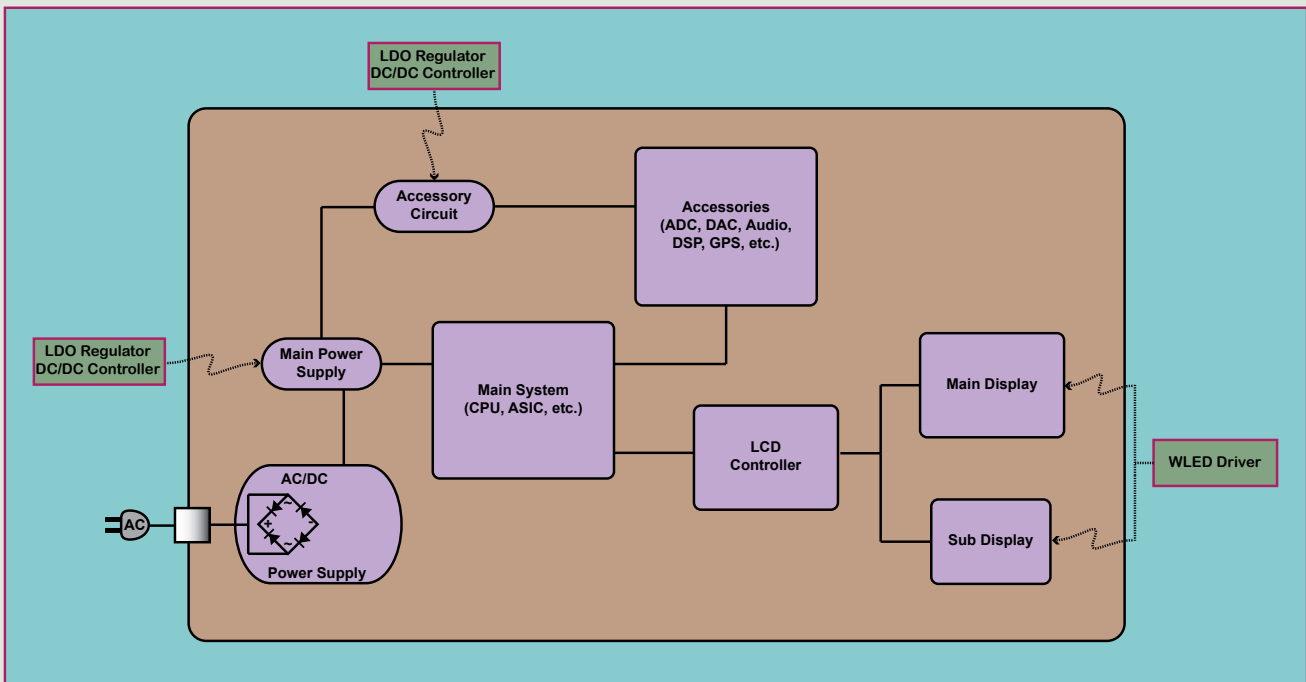

Selection Guide

DC/DC Controller/Converter

Type Specification P/N	Type	Channel	V _{OP}	V _{OUT}	I _{OUT}	Switching Tr.	Rectifier	V _{REF}	T _{OP}	f _{sw}	Current Protection	Power Good	Package
AL1014 AL1014	Step Down	1	4.5 to 22V	1.24 to V _{IN}	3A	Ext	Ext	± 2%	-30°C to +85°C	220kHz	Timer Latch		SSOP-8
AL1015 AL1015	Step Down	1	4.5 to 22V	1.24 to V _{IN}	3A	Ext	Ext	± 2%	-30°C to +85°C	220kHz	Auto recovery		SSOP-8
AL1016 AL1016	Step Down	1	4.5 to 22V	1.24 to V _{IN}	3A	Ext	Ext	± 1%	-30°C to +85°C	220kHz	Timer Latch		SSOP-8
AL1025 AL1025	Step Up	1	4.5 to 22V	to V _{IN} *8	1A	Ext	Ext	± 2%	-30°C to +85°C	220kHz	Auto recovery		SSOP-8
AL1040 AL1040	Step Down	1	4.5 to 36V	0.8 to 6.3V	10A	Ext	Ext	± 1%	-40°C to +85°C	200kHz 300kHz 400kHz 550kHz	Fold-back	✓	TSSOP-16
AL1042 AL1042	Step Down	1	4.5 to 36V	0.8 to 6.3V	10A	Ext	Ext	± 1%	-40°C to +85°C	200kHz 300kHz 400kHz 550kHz	Fold-back	✓	TSSOP-16
AL1044 AL1044	Step Down	1	4.5 to 36V	0.8 to 6.3V	10A	Ext	Ext	± 1%	-40°C to +85°C	300kHz 400kHz 550kHz	Fold-back	✓	TSSOP-16
AL1055 AL1055	Step Down	2	4.5 to 36V	0.8 to 6.3V	10A	Ext	Ext	± 1%	-40°C to +85°C	200kHz 300kHz 400kHz 550kHz	Fold-back	✓	VSOP-30
AL1061 AL1061	Step Down	1	4.5 to 33V	1.24 to V _{IN}	3A	Ext	Ext	± 2%	-30°C to +85°C	300kHz	Timer Latch		SSOP-16
AL1080 AL1080	Step Down	1	4.5 to 33V	0.62 to 5.5V	4A	Ext	Ext	± 1%	-30°C to +85°C	100k to 500kHz	Fold-back		SSOP-16
AL1270 AL1270	Step Down	1	4.5 to 33V	0.62 to 5.5V	4A	Ext	Ext	± 1%	-30°C to +85°C	100k to 500kHz	Fold-back		SSOP-16
AL1463 AL1463	Step Down	1	5.5 to 27V	1.24 to V _{IN} -0.5V	4A	Ext	Ext	± 1%	-30°C to +85°C	100k to 500kHz	Timer Latch		SSOP-16
<i>Low Current energy saving mode</i>													
AL1473 AL1473	Step Down	1	4.5 to 27V	0.62 to 5.5V	4A	Ext	Ext	± 1%	-30°C to +85°C	100k to 500kHz	Timer Latch		SSOP-16
AL2010 AL2010	Step Down	1	3.0 to 5.5V	0.8 to 5V	2A	Int	Ext	± 1.5%	-40°C to +85°C	300k to 4MHz	Hiccup	✓	SSOP-16
AL2040 AL2040	Step Down	1	4.0 to 0.5V	0.8 to V _{IN} -0.5V	10A	Ext	Ext	± 1%		300k to 1MHz	Hiccup	✓	SSOP-16
AL2070 AL2070	Step Down	1	4.5 to 27V	0.62 to 5.5V	10A	Ext	Ext	± 1%	-30°C to +85°C	100k to 500kHz	Timer Latch	✓	SSOP-16
AK7956A AK7956AP-8	Step Up	1	4.5 to 5.5V	6 to 12V	125mA	Int	Int	± 5%	-40°C to +85°C	1.25MHz	Fold-back		USON-8
TK6015xAB6 TK6015xAB6GHB	Step Down	1	2.8 to 5.5V	1.2 to 3.3V	400mA	Int	Int	-	-40°C to +85°C	1.2MHz	Timer Latch		FC-8
<i>With built in 100mA LDO for increased efficiency in low power mode</i>													
TK82596AU3 TK82596AU3GOL	Step Down	1	4.5 to 40	1.23 to 37V	3A	Int	Ext	± 3%	-40°C to +125°C	150kHz	-		TO252-5

LDOs

Type Specification P/N	V _{OP}	V _{OUT} (tolerance)	I _{OUT} (MAX)	V _{DROP} @ I _{OUT}	I _Q @ I _O =0mA	On/off control	Ripple Rejec- tion	P _D	Package
TK11100CS TK11100CSCB-GH	2.1 to 14.0V	1.3 to 13.0V	200mA (320mA)	200mV @200mA	78µA	Active high	-80dB	500mW	SOT23-6
TK111XXCS TK111xxCSCL-G	2.1 to 14.0V	1.5 to 10.0V ±(1.5% or 50mV)	200mA (320mA)	200mV @200mA	63µA	Active high	-80dB	500mW	SOT23-5
TK112XXCM TK112xxCMCL-GH	2.1 to 14.5V	1.5 to 10.0V ±(1.5% or 50mV)	300mA (380mA)	235mV @300mA	65µA	Active high	-80dB	600mW	SOT23L-6
TK112XXCU TK112xxCUCB-G	2.1 to 14.5V	1.5 to 10.0V ±(1.5% or 50mV)	300mA (380mA)	235mV @300mA	65µA	Active high	-80dB	900mW	SOT89-5
TK113XXCM TK113xxCMCL-GH	2.1 to 14.5V	1.5 to 10.0V ±(2.0% or 60mV)	300mA (380mA)	235mV @300mA	80µA	Active low	-80dB	600mW	SOT23L-6
TK631XXBB6 TK631XXBB6GHB-C	2.0 to 6.0V	1.5 to 4.2V (± 1.0%)	200mA (210mA)	80mV @100mA	80µA	Active high	-70dB	360mW	FC-4
TK631XXH TK631xxHCL-GH	2.0 to 6.0V	1.5 to 4.2V (±1.0%)	200mA (210mA)	80mV @100mA	80µA	Active high	-70dB	500mW	SON 2017-6
TK631XXS TK631xxSCL-G	2.0 to 6.0V	1.5 to 4.2V (±1.0%)	200mA (210mA)	80mV @100mA	80µA	Active high	-70dB	500mW	SOT23-5
TK634XXAMF TK634xxAMFGHL-C	1.8 to 6.0V	1.5 to 4.2V ±(1.0% or 25mV)	200mA (210mA)	165mV @200mA	35µA	Active high	-72db	400mW	HSO N1214-4
TK635XXAB6 TK635xxAB6GHB-C	2.0 to 6.0V	1.5 to 4.2V ±(1.0% or 25mV)	200mA (210mA)	165mV @200mA	45µA	Active high	-75db	360mW	FC-4
TK637XXAB6 TK637xxAB6GHB-C	1.8 to 6.0V	1.5 to 4.2V ±(2.0% or 60mV)	150mA (200mA)	80mV @50mA	10µA	Active high	-65dB	360mW	FC-4
TK637XXH TK637xxHCL-GH	1.8 to 6.0V	1.5 to 4.2V ±(2.0% or 60mV)	150mA (200mA)	90mV @50mA	10µA	Active high	-65dB	500mW	SON 2017-6
TK637XXS TK637xxSCL-G	1.8 to 6.0V	1.5 to 4.2V ±(2.0% or 60mV)	150mA (200mA)	90mV @50mA	10µA	Active high	-65dB	500mW	SOT23-5
TK638XXAMH TK638xxAMHGHL-C	2.0 to 6.0V	1.5 to 4.2V ±(2.0% or 60mV)	150mA (200mA)	90mV @50mA	10µA	Active high	-70dB	500mW	HSO N1820A-6
TK642XXBB6 TK642xxBB6GHB-C	1.8 to 6.0V	1.2 to 4.2V ±(1.0% or 25mV)	200mA (210mA)	200mV+ 200mV @200mA	35µA/ch	Active high	-75db	600mW	FC-6
TK643XXBB6 TK643xxBB6GHB-C	1.8 to 6.0V	1.2 to 4.2V ±(2.0% or 60mV)	200mA (210mA)	180mV+ 180mV+ 180mV @200mA	40µA/ch	Active high	-70db	810mW	FC-9
TK647XXAB6 TK647xxAB6GHB-C	2.0 to 6.0V	1.5 to 4.2V (± 1.0%)	200mA (210mA)	175mV @200mA	40µA	Active high	-75db	360mW	FC-4
TK648XXAMF TK648xxAMFGHL-C	1.8 to 6.0V	1.2 to 4.2V ±(1.0% or 25mV)	300mA (310mA)	245mV @300mA	35µA	Active high	-72db	400mW	HSO N1214-4
TK681XXAMF TK681xxAMFG0L-C	1.7 to 6.0V	1.2 to 4.2V ±(1.0% or 25mV)	200mA (210mA)	85mV @100mA	12µA	Active high	-52dB	400mW	HSO N1214-4
TK681XXAS2 TK681xxAS2GHL	1.7 to 6.0V	1.2 to 4.2V ±(1.0% or 25mV)	200mA (210mA)	85mV @100mA	12µA	Active high	-52dB	400mW	SOT23-5
TK682XXAB6 TK682xxAB6GHB-C	1.8 to 6.0V	1.2 to 4.2V ±(2.0% or 60mV)	200mA (210mA)	240mV @200mA	10µA	Active high	-55db	600mW	FC-6
TK684XXAB6 TK684xxAB6GHB-C	1.7 to 6.0V	1.2 to 4.2V ±(2.0% or 60mV)	200mA (210mA)	115mV @100mA	10µA	Active high	-53dB	360mW	FC-4
TK684XXAB9 TK684xxAB9GHB-C	1.7 to 6.0V	1.2 to 4.2V ±(2.0% or 60mV)	200mA (210mA)	115mV @100mA	10µA	Active high	-53dB	360mW	FC- 3050B-4
TK685XXAS2 TK685xxAS2GHL-C	1.8 to 6.0V	1.2 to 4.2V ±(2.0% or 60mV)	200mA (210mA)	180mV @200mA	1µA	Active high	-30db	500mW	SOT23-5

TOP is -40°C to 85°C

Selection Guide

LDOs (continued)

Type Specification P/N	V _{OP}	V _{OUT} (tolerance)	I _{OUT} (MAX)	V _{DROP} @ I _{OUT}	I _Q @ I _O =0mA	On/off control	Ripple Rejec- tion	P _D	Package
TK687XXAMF TK687xxAMFGHL-C	1.8 to 6.0V	1.2 to 4.2V ±(2.0% or 60mV)	150mA (210mA)	275mV @150mA	1µA	Active high	-34dB	400mW	HSO N 1214-4
TK705XXS TK705xxSCL-G	2.1 to 14.0V	1.3 to 5.0V ±(1.5% or 50mV)	100mA (150mA)	160mV @100mA	75µA	Active high	-80dB	460mW	SOT23-5
TK706XXH TK706xxHCL-GH	2.1 to 14.0V	1.3 to 5.0V ±(1.5% or 50mV)	100mA (150mA)	160mV @100mA	75µA	Active high	-80dB	400mW	SON 2017-6
TK717XXS TK717xxSCL-G	2.1 to 14.0V	1.5 to 5.0V ±(1.5% or 50mV)	200mA (280mA)	163mV @200mA	72µA	Active high	-80dB	500mW	SOT23-5
TK72100CS TK72100CSGB-GH	-2.8 to -19.0V	-3.0 to -17.5V	150mA (200mA)	290mV @50mA	170µA	Active low	-52dB	500mW	SOT23-6
TK721XXCS TK721xxCSCL-GH	-2.8 to -19.0V	-2.0 to -9.5V ±(2.0% or 60mV)	150mA (200mA)	290mV @50mA	155µA	Active low	-49dB	500mW	SOT23-5
TK72200CS2 TK72200CS2GHB-C	-3.0 to -19.0V	-3.0 to -17.5V	150mA (200mA)	290mV @50mA	170µA	Active high	-45dB	500mW	SOT23-6
TK722XXCS TK722xxCSCL-GH	-3.0 to -19.0V	-5.0V ±(2.0% or 60mV)	150mA (200mA)	290mV @50mA	155µA	Active high	-42dB	500mW	SOT23-5
TK73400AU3 TK73400AU3G0L-C	2.4 to 15.0V	1.3 to 12.0V	1A (1.4A)	150mV @500mA	300µA	Active high	-78dB	830mW	TO252-5
TK736XXAU3 TK736xxAU3G0L-C	2.4 to 15.0V	1.5 to 12.0V ±(2.0% or 50mV)	1A (1.4A)	160mV @500mA	320µA	Active high	-80dB	3W	TO252-5
TK736XXAME TK736xxAMEG0L-C	2.4 to 15.0V	1.5 to 12.0V ±(2.0% or 50mV)	1A (1.4A)	160mV @500mA	320µA	Active high	-80dB	2.4W	HSOP-8
TK771XXAMG TK771xxAMGG0L	2.9 to 14.5V	0.8 to 12V ±(2% or 60mV)	150mA (160mA)	550mV @150mA	90µA	Active high	-65db	1W	HSO N 1414-6
TK772XXAMH TK772xxAMHG0L	2.5 to 14.5V	0.8 to 12V ±(2% or 50mV)	300mA (350mA)	500mV @300mA	150µA	Active high	-56dB	900mW	HSO N 1820A-6
TK773XXAM4 TK773xxAM4G0L	2.5 to 14.5V	0.8 to 12V ±(2% or 60mV)	500mA (520mA)	500mV @500mA	150µA	Active high	-60db	600mW	SON 3024-8
TK773XXAME TK773xxAMEG0L	2.5 to 14.5V	0.8 to 12V ±(2% or 50mV)	500mA (520mA)	500Mv @500mA	150µA	Active high	-60db	2W	HSOP-8
TK774XXAMH TK774xxAMHGHL	1.2 to 6.0V	0.8 to 5.0V ±(2% or 60mV)	300mA (450mA)	600mV @300mA	90µA	Active high	-50db	900mW	HSO N 1820A-6
TK775XXAM4 TK775xxAM4GHL	1.2 to 6.0V	0.8 to 5.0V ±(2% or 60mV)	500mA (520mA)	500mV @500mA	250µA	Active high	-48db	600mW	SON 3024-8
TKG00XXAB6 TKG00xxAB6GHB	V _{IN} =1.2 to 3.0 V _{Bat} =2.6 to 6.0	1.2 to 2.0V (±30mV)	350mA (360mA)	95mV (V _{IN} -V _O) 1.2V (V _{Bat} -V _O) @350mA	10µA (I _{IN}) 45µA (I _{Bat})	Active high	-80db(V _{IN}) -60db(V _{Bat})	450mW	FC-5
TKG02XXAB7 TKG02xxAB7GHB	2.0 to 6.0V	1.2 to 4.2V ±(1.0% or 25mV)	200mA (210mA)	160mV @200mA	40µA	Active high	-80dB	780mW	FC2540-4
TKG03XXAB6 TKG03xxAB6GHB	1.8 to 6.0V	1.2 to 4.2V ±(2.0% or 60mV)	200mA (210mA)	180mV @200mA	40µA (4.5µA sleep)	Active high	-65dB	1.3W	FC 3050B-8
TKG04XXAB6 TKG04xxAB6GHB	2.0 to 6.0V	1.2 to 4.2V ±(1.0% or 25mV)	300mA (310mA)	275mV @300mA	40µA	Active high	-75dB	360mW	FC-4
TKG05XXAS2 TKG05xxAS2GHL	3.3 to 19V	2.0 to 18V ±(1.5% or 50mV)	150mA (160mA)	1150mV @150mA	5µA	Active high	-45dB	200mW	SOT23-5
TKG05XXAU1 TKG05xxAU1GHL	3.3 to 19V	2.0 to 18V ±(1.5% or 50mV)	150mA (160mA)	1150mV @150mA	5µA	Active high	-45dB	900mW	SOT89-5

TOP is -40°C to 85°C

Active Noise Filter

Type Specification P/N	V _{OP}	I _{OUT}	V _{DROP} @ I _O	I _Q @ I _O =0mA	On/off control	Ripple Rejection	P _D	Package
TK70008S TK70008STL-G	1.8 to 16.0V	to 150mA	300mV (programmable)	65µA	Active high	-66dB	500mW	SOT23-5
TK70010AME TK70010AMEGHL	2.4 to 15.0V	to 1A	300mV (programmable)	300µA	Active high	-65dB	2.4W	HSOP-8

White LED Flash Driver

Type Specification P/N	V _{OP}	Num. of LED	LED Current	Efficiency	Type	Switching Tr.	System	T _{OP}	P _D	f _{sw}	Package
TK11890AB1 TK11890AB1G0B	2.65 to 8.0V	Series 2 to 4	100mA	80%	Step Up	Int	Inductive External schottky	-30 to +85°C	600mW	2MHz	FC-9
TK11891F TK11891FTL-GH	2.65 to 16.0V	Series 2 to 4	100mA	80%	Step Up	Int	Inductive External schottky	-30 to +85°C	600mW	2MHz	SON 3024-8
TK11892F TK11892FTL-GH	2.65 to 8.0V	Series 2 to 4	100mA	80%	Step Up	Int	Inductive External schottky	-30 to +85°C	600mW	2MHz	SON 3024-8
TK11894AM8 TK11894AM8G0B	2.5 to 6.0V	Series 1 to 2	725mA	80%	Step Up	Int	Inductive External schottky	-30 to +85°C	1W	2MHz	HSO 3030B-10
TK11895AB6 TK11895AB6GHB	2.65 to 8.0V	Series 2 to 4	100mA	80%	Step Up	Int	Inductive External schottky	-30 to +85°C	600mW	2MHz	FC-9
TK11898AB6 TK11898AB6GHB	2.5 to 5.5V	Series 1 or 2	900mA	80%	Step Up	Int	Inductive External schottky	-30 to +85°C	1W	1.8MHz	FC 3050-16
AP2060A/B TBD	2.6 to 5.5V	Parallel 1 or 2	1000mA	TBD	Step Up	Int	Inductive External schottky	-40 to +85°C	TBD	2MHz	UQFN-16 CSP-16

Linear Constant Current LED Driver



















Type Specification P/N	V _{OP}	Number of LED	LED Current Matching	T _{OP}	P _D	Package
TK60033AB7 TK60033AB7GHL	2.7 to 5.5V	Parallel 1 to 6	1%	-40 to +85°C	1W	FC2540-12
TK60034AB7 TK60034AB7	2.7 to 5.5V	Parallel 1 to 4	1%	-40 to +85°C	720mW	FC2540-9
TK60036AB7 TK60036AB7	2.7 to 5.5V	1	-	-40 to +85°C	330mW	FC2540-4



















Selection Guide

White LED Driver

Type Specification P/N	V _{OP}	Num. of LED	LED Current	Efficiency	Type	Switching Tr.	System	T _{OP}	P _D	f _{sw}	Package
AP2000A AP2001A4Q71H-E2	8 to 28V	8 CH by 12	40mA	93%	Step Up	Int	Inductive External Schottky	-40°C to +85°C	2W	1.5MHz	HQFN 4040B-24
AP2001A AP2001A4Q71H-E2	8 to 28V	8 CH by 12	40mA	93%	Step Up	Int	Inductive External Schottky	-40°C to +85°C	2W	1.5MHz	HQFN 4040B-24
TK11840L TK11840LTL-GH	1.8 to 10.0V	Series 2 or more	-	80%	Step Up	Ext	Inductive External Schottky	-20°C to +85°C	400mW	to 1MHz	SOT23L-8
TK11851L TK11851LTL-GH	2.3 to 10.0V	Series 2 to 4	15mA	80%	Step Up	Int	Inductive External Schottky	-30°C to +85°C	400mW	800kHz	SOT23L-8
TK11855F TK11855FTL-GH	2.65 to 16.0V	Series 2 to 4	20mA	85%	Step Up	Int	Inductive External Schottky	-30°C to +85°C	600mW	570kHz	SON 3024-8
TK11859F TK11859FTL-GH	2.30 to 16.0V	Series 2 to 4	20mA	83%	Step Up	Int	Inductive External Schottky	-30°C to +85°C	600mW	1.2MHz	SON 3024-8
TK11880F TK11880FTL-GHJ	2.65 to 10.0V	Series 2 to 6	30mA	80%	Step Up	Int	Inductive External Schottky	-30°C to +85°C	600mW	1MHz	SON 3024-8
TK61220AQ4 TK61220AQ4G0B	3 to 14.0V	2 CH -	-	83%	Step Up	Ext	Inductive External Schottky	-40°C to +105°C	2.5W	2.2MHz	HQFN 4040-24
TK61222CQ6 TK61222CQ6GHB	4.25 to 25V	6 CH by 10	25mA	83%	Step Up	Int	Inductive External Schottky	-40°C to +125°C	2W	200kHz to 2MHz	HQFN 4040A-24
TK61223AQ8 TK61222AQ8GHB	4.25 to 25V	8 CH by 10	30mA	83%	Step Up	Int	Inductive External Schottky	-40°C to +105°C	TBD	200kHz to 2.5MHz	HQFN 4040C-24
TK61225AQ7 TK61225AQ7GHB	4.25 to 28V	8 CH by 10	25mA	83%	Step Up	Int	Inductive External Schottky	-40°C to +85°C	2W	1MHz	HQFN 4040B-24
TK61226AMQ TK61225AMQGHL	4.25 to 35V	3 CH by 8	120mA	83%	Step Up	Int	Inductive External Schottky	-40°C to +105°C	2.5W	200kHz to 2.5MHz	HT SSOP-20
TK61227AM8 TK61227AM8GHB	2.5 to 35V	2 CH by 10	25mA	83%	Step Up	Int	Inductive External Schottky	-40°C to +105°C	TBD	1.2MHz	HSO 3030B-8
TK61290M8 TK61290M8GHB	2.65 to 5.55V	Series 2 to 10	20mA	83%	Step Up	Int	Inductive External Schottky	-40°C to +105°C	1A	600kHz	HSO 3030B-8
TK65604AB6 TK65604AB6GHB	2.7 to 5.5V	Series 2 to 4	20mA	84%	Step Up	Int	Inductive Internal Rectifier	-30°C to +85°C	660mW	1.3MHz	FC 3050A-8

Package Guide

Package Name	Outline	LxWxH (mm)	Pitch (mm)
FC-4		0.96x0.96x0.06 1.06x1.06x0.60	0.5
FC-5		1.33x1.06x0.60 1.33x0.96x0.60	0.5
FC-6		1.46x0.96x0.60 1.61x1.11x0.60	0.5
FC-8		1.46x1.46x0.60 1.66x1.66x0.60	0.5
FC-9		1.46x1.46x0.60 1.76x1.76x0.60	0.5
FC2540-4		0.76x0.76x0.60	0.4
FC2540-9		1.16x1.16x0.60	0.4
FC2540-12		1.16x1.56x0.60	0.4
FC3050B-4		0.96x0.96x0.30	0.5
FC3050-8		1.46x1.46x0.60	0.5
FC3050A-8		1.66x1.66x0.60	0.5
FC3050B-8		2.11x2.11x0.60	0.5
FC3050-16		2.11x2.11x0.60	0.5
HQFN4040-24		4.0x4.0x0.90	0.5
HQFN4040A-24		4.0x4.0x0.90	0.5
HQFN4040B-24		4.0x4.0x0.90	0.5
HQFN4040C-24		4.0x4.0x0.90	0.5
HSO1214-4		1.2x1.4x0.55	0.5

Package Name	Outline	LxWxH (mm)	Pitch (mm)
HSO1414-6		1.4x1.4x0.55	0.5
HSO1820A-6		1.8x2.0x0.65	0.5
HSO3030B-10		3.0x3.0x0.90	0.65
HSOP-8		4.9x6.0x1.45	1.27
HTSSOP-20		6.5x6.4x1.2	0.65
SON 2017-6		2.0x2.1x0.75	0.65
SON3024-8		3.0x2.8x0.75	0.65
SOT23-5		2.9x2.8x1.1	0.95
SOT23-6		2.9x2.8x1.1	0.95
SOT23L-6		3.4x3.3x1.2	0.95
SOT23L-8		3.4x3.3x1.2	0.95
SOT89-5		4.5x4.5x1.5	1.5
SSOP-8		3.0x4.9x1.1	0.65
SSOP-16		5.0x6.4x1.1	0.65
TO252-5		6.5x9.90x2.30	1.29
TSSOP-16		5.0x6.4x0.9	0.65
USON-8		3.0x3.0x0.60	0.65
VSOP-30		9.7x7.6x1.2	0.65



AKM worldwide offices

Americas

AKM Semiconductor

1731 Technology Drive
Suite 500, San Jose, CA 95110
Tel: 408-436-8580
888-256-7364
Fax: 408-436-7591

Europe

Europe Headquarters

333 Bureaux de la Colline
92213 St Cloud, Paris, France
Tel: +33 1 41 12 80 40
Fax: +33 1 47 11 08 35

UK Branch

Market House, 19/21 Market
Place, Wokingham, Berkshire
RG40 1AP United Kingdom
Tel: +44-118-979-5777
Fax: +44-118-979-7885

Korea

Korea Headquarters

8F, KTP B/D, 27-2, Yoido-dong
Youngdungpo-gu, Seoul 150-742 Korea
Tel: +82-2-3775-0990
Fax: +82-2-3775-1991

Asahi Kasei Microdevices Corporation

Corporate Headquarters

1-105 Kanda Jinbocho, Tokyo
101-8101, Japan
Tel: +81-3-3296-3941
Fax: +81-3-3296-3932

China

China Headquarters

23F, Shanghai Central Plaza, 381
Huaihai Zhong Road, Shanghai, 200020, China
Tel: +86-21-6391-5500
Fax: +86-21-6391-5255

Beijing Office

Tel: +86-10-6569-3939

Shenzhen Office

Tel: +86-136-0269-8519

Taiwan

Taiwan Headquarters

9F, No.275, Sec3, Nanjing E.Rd., Songshan
Dist., Taipei City 10550 Taiwan (R.O.C.)
Tel: +886-2-2546-2260
Fax: +886-2-2546-2265

AsahiKASEI