



AP1019

9.0V Dual H-Bridge Motor Driver IC

1. General Description

The AP1019 is a dual H-Bridge Motor Driver to operate up to 9.0V power supply. It has four drive modes of operation; Forward, Reverse, Brake and Standby. It is capable to configure the input logic which is suitable for the PWM drive with the SEL terminal. The driver works up to 1MHz, therefore it can suppress the current ripple and reduce the motor sound.

The AP1019 has an N-ch LDMOS FET for both high side and low side of the output circuit, realizing to adopt a small WL-CSP package. In addition, the AP1019 has under-voltage detection and thermal shutdown circuits. It is suitable for driving various small motors.

2. Features

- | | |
|-----------------------------------|-------------------------------|
| • Wide Motor Driving Voltage | 1.4V to 9.0V |
| • Power Supply Voltage | 2.7V to 5.5V |
| • Maximum Output Current (DC) | 1.1A (max) |
| • Maximum Output Current (Peak) | 2.0A (Ta=25°C, 10ms/200ms) |
| • H-Bridge ON Resistance | RON (TOP+BOT)=0.35Ω @Ta=25°C |
| • PWM Operation Frequency | 1MHz(max) |
| • Under Voltage Detection Circuit | |
| • Thermal Shut Down Circuit | |
| • Operation Temperature Range | -30 ~ 85°C |
| • Package | 16-pin WLCSP (1.96mm×1.96mm) |

3. Table of Contents

1. General Description	1
2. Features	1
3. Table of Contents	2
4. Block Diagram	3
5. Pin Configurations and Functions	4
5.1. Pin Configurations	4
5.2. Functions	4
6. Absolute Maximum Ratings	5
7. Recommended Operating Conditions	6
8. Electrical Characteristics	6
9. Functional Descriptions	8
9.1 Control Logic	8
9.2 Protection Functions	9
9.3 Linearity Characteristic under PWM Control	11
10. Recommended External Circuits	12
11. Package	13
11.1. Outline Dimensions	13
11.2. Marking	13
12. Ordering Guide	14
13. Revision History	14
IMPORTANT NOTICE	15

4. Block Diagram

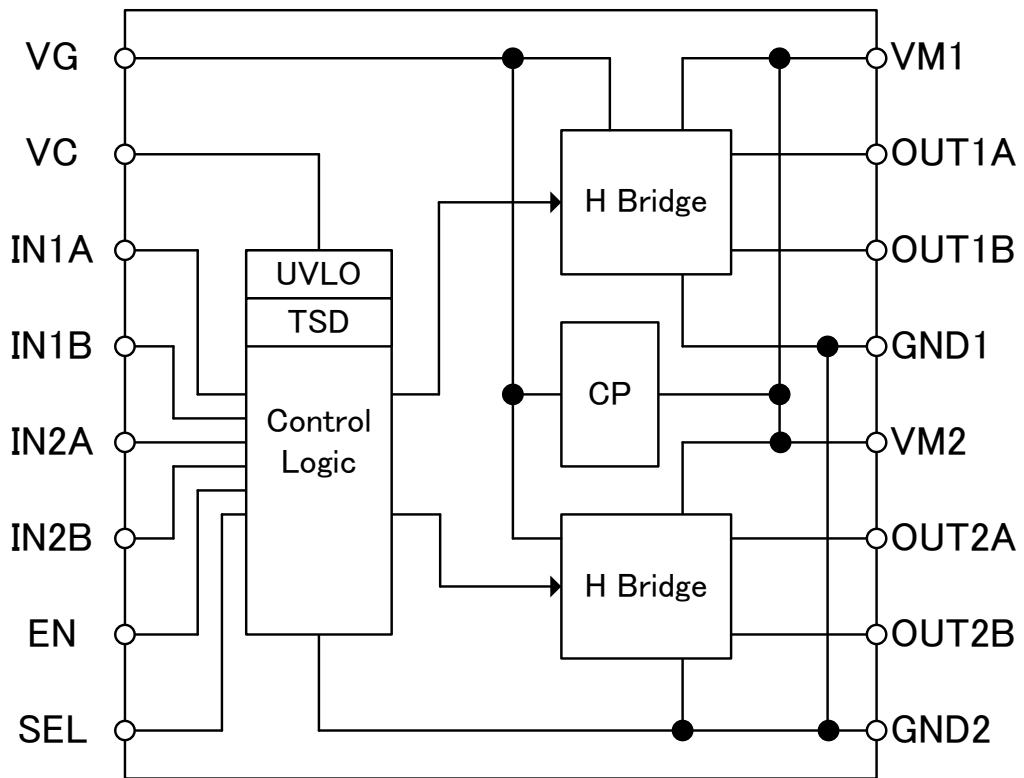
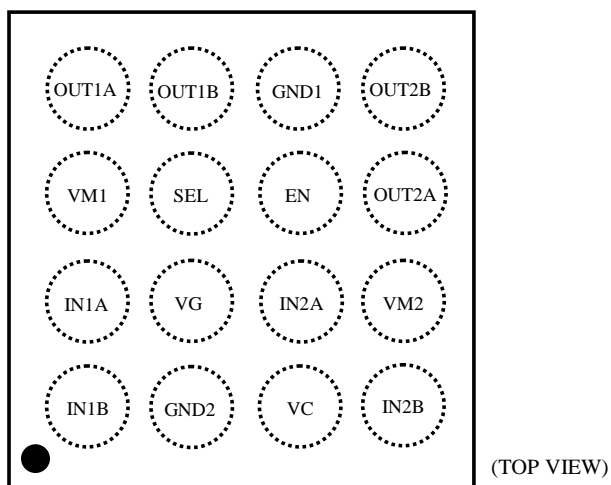

Figure 1. Block Diagram

5. Pin Configurations and Functions

5.1. Pin Configurations



5.2. Functions

Pin Number	Name	I/O (Note 1)	Functions	Remarks
A1	IN1B	I	Control signal input terminal	
A2	IN1A	I	Control signal input terminal	
A3	VM1	P	Motor driver power supply	(Note 2)
A4	OUT1A	O	Motor driver output Terminal	
B1	GND2	P	Power ground terminal	(Note 3)
B2	VG	P	Charge pump output capacitor connection terminal	
B3	SEL	I	Input logic selection terminal	200kΩ Pull-down
B4	OUT1B	O	Motor driver output Terminal	
C1	VC	P	Control power supply	
C2	IN2A	I	Control signal input terminal	
C3	EN	I	Enable signal input terminal	200kΩ Pull-down
C4	GND1	P	Power ground terminal	(Note 3)
D1	IN2B	I	Control signal input terminal	
D2	VM2	P	Motor driver power supply	(Note 2)
D3	OUT2A	O	Motor driver output Terminal	
D4	OUT2B	O	Motor driver output Terminal	

Note 1. I (Input terminal), O (Output terminal) and P (Power terminal)

Note 2. Connect the VM1 and VM2 terminals on the PCB. These terminals must be connected to the same power supply voltage.

Note 3. Connect the GND1 and GND2 terminals on the PCB. These terminals must be connected to the same ground.

6. Absolute Maximum Ratings

Parameter	Symbol	Min.	Max.	Unit	Condition
Control Supply Voltage	VC	-0.3	6.0	V	
Motor Supply Voltage	VM	-0.3	10.0	V	
VC Level Terminal Voltage (INnA, IN1nB, SEL and EN)	V _{terminal1}	-0.3	VC	V	
VM level Terminal Voltage (OUTnA and OUTnB)	V _{terminal2}	-0.3	VM	V	
VC+VM Level Terminal Voltage (VG)	V _{terminal3}	-0.3	16.0	V	
Maximum Output Current @2ch drive	I _{loaddcMD}	-	1.1	A/ch	Ta = 25°C
		-	0.8	A/ch	Ta = 85°C
Maximum Output Current @1ch drive	I _{loaddcMD}	-	1.5	A	Ta = 25°C
		-	1.1	A	Ta = 85°C
Maximum Output Peak Current	I _{loadpeakMD}	-	2.0	A	Within 10ms during 200ms
Power Dissipation	PD	-	1760	mW	Ta = 25°C (Note 5)
		-	915	mW	Ta = 85°C (Note 5)
Junction Temperature	T _j		150	°C	
Storage Temperature	T _{stg}	-65	150	°C	

Note 4. All above voltage are with respect to GND.

Note 5. This is calculated as RθJ = 71°C/W using a 2-layer board.

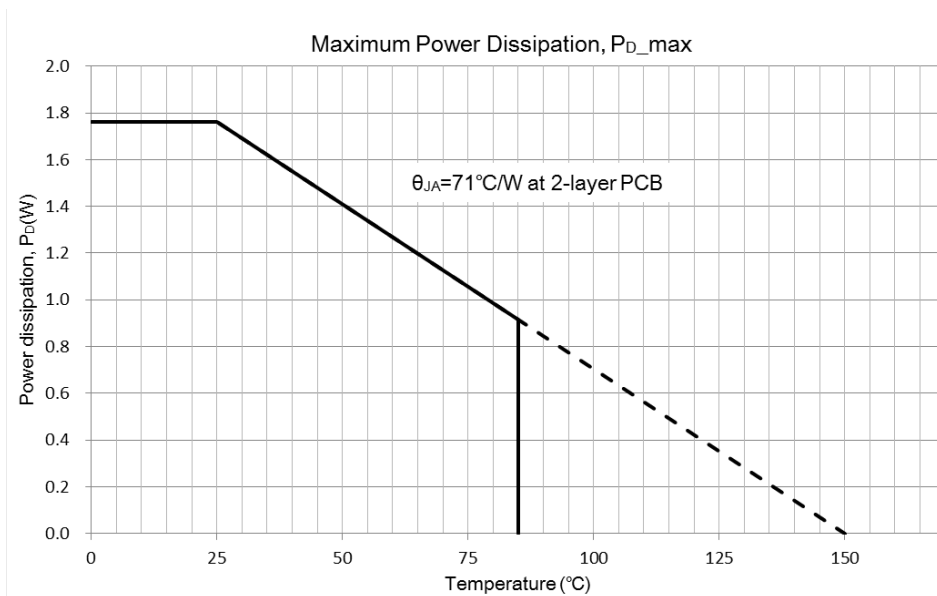

Figure 2. Maximum Power Dissipation

WARNING: Operation at or beyond these limits may result in permanent damage to the device. Normal operation is guaranteed at these extremes.

7. Recommended Operating Conditions

(Ta = 25°C, unless otherwise specified)

Parameter	Symbol	Min.	Typ.	Max.	Unit	Condition
Control Supply Voltage	VC	2.7	3.0	5.5	V	
Motor Driver Supply Voltage	VM	1.4	5.0	9.0	V	
Input Pulse Frequency 1	FIN1	-	-	1000	kHz	VM=2V~9V 50%duty
Input Pulse Frequency 2	FIN2	-	-	400	kHz	VM=1.4V~ 9V 50%duty
Operating Temperature Range	Ta	-30	-	85	°C	

8. Electrical Characteristics

(Ta = 25°C, VM=5.0V, VC = 3.0V, unless otherwise specified)

Parameter	Symbol	Condition	Min.	Typ.	Max.	Unit
Quiescent Current						
VM Quiescent Current at Power Off	I _{VMPOFF}	EN="L" All internal circuits are power off.	-	-	1.0	μA
VC Quiescent Current at Power Off	I _{VCPOFF}		-	-	1.0	μA
VM Quiescent Current at Standby	I _{VMSTBY}	EN="H", SEL="L" INnA="L", INnB="L"	-	40	200	μA
VC Quiescent Current at Standby	I _{VCSTBY}		-	150	500	μA
VC Quiescent Current at PWM Operation	I _{VCPWM1}	FIN=1000kHz(INnA), SEL="L", INnB="H" Duty=50%	-	2.0	5.0	mA
	I _{VCPWM2}	FIN=1000kHz(INnB), SEL="L", INnA="H" Duty=50%	-	3.3	10.0	mA
Charge Pump						
Charge Pump Voltage	VG	VG=VC+VM, Iload=0A	7.0	7.5	8.0	V
Charge Pump Wake Up Time	t _{VGON}	VG=VC+VM-1.0V	-	0.3	3.0	ms
Motor Driver						
Driver On-resistance (High side + Low side)	R _{ON1}	Iload=100mA, Ta=25°C	-	0.35	0.46	Ω
Driver On-resistance (High side + Low side) (Note 6)	R _{ON2}	Iload=0.7A, Ta=25°C	-	0.38	0.53	Ω
Driver On-resistance (High side + Low side) (Note 6)	R _{ON3}	Iload=0.7A, Ta=85°C	-	0.48	0.72	Ω
Body Diode Forward Voltage	V _{FMD}	I _F =100mA	-	0.8	1.2	V
H-Bridge Propagation Delay Time (L→H)	t _{PDH}	tr=tf=10ns, 1kΩ Load between OUTnA and OUTnB. (Figure 3 (a))	-	-	0.5	μs
H-Bridge Propagation Delay Time (H→L)	t _{PDL}		-	-	0.5	μs
H-Bridge Propagation Delay Time (Hi-Z→"H") (Note 6)	t _{PDZH}		-	-	0.5	μs
H-Bridge Propagation Delay Time (Hi-Z→"L") (Note 6)	t _{PDZL}		-	-	0.5	μs
H-Bridge Output Pulse Width (Note 6)	t _{PWO}	20Ω Load between OUTA and OUTB. Input Pulse Width t _{PWI} : 100ns(Figure 3 (b))	35	85	135	ns

Parameter	Symbol	Condition	Min.	Typ.	Max.	Unit
Control Logic						
Input High Level Voltage (INnA, INnB, SEL and EN)	V_{IH}	$V_C=2.7V\sim 5.5V$	0.7 $\times V_C$	-	-	V
Input Low Level Voltage (INnA, INnB, SEL and EN)	V_{IL}		-	-	0.3 $\times V_C$	V
Input High Level Current (INnA and INnB)	I_{IH1}	$V_{IH}=3.0V$	-1.0	0	1.0	μA
Input High Level Current (SEL and EN)	I_{IH2}	$V_{IH}=3.0V$	9	15	21	μA
Input Low Level Current (INnA, INnB, SEL and EN)	I_{IL}	$V_{IL}=0V$	-1.0	-	1.0	μA
Protection						
VC Under-voltage Detect Voltage	$V_{C_{UV}}$		1.9	2.2	2.5	V
Voltage Hysteresis	$V_{C_{UVHYS}}$	Design guarantee (Note 6)	0.02	0.05	0.2	V
Thermal Shutdown temperature	T_{DET}	Design guarantee (Note 6)	150	175	200	$^{\circ}C$
Temperature Hysteresis	T_{DETHYS}	Design guarantee (Note 6)	15	25	35	$^{\circ}C$

Note 6. Not tested in production.

Note 7. 10Ω Load between OUTnA/B and GND. 10Ω Load between OUTnA/B and VM.

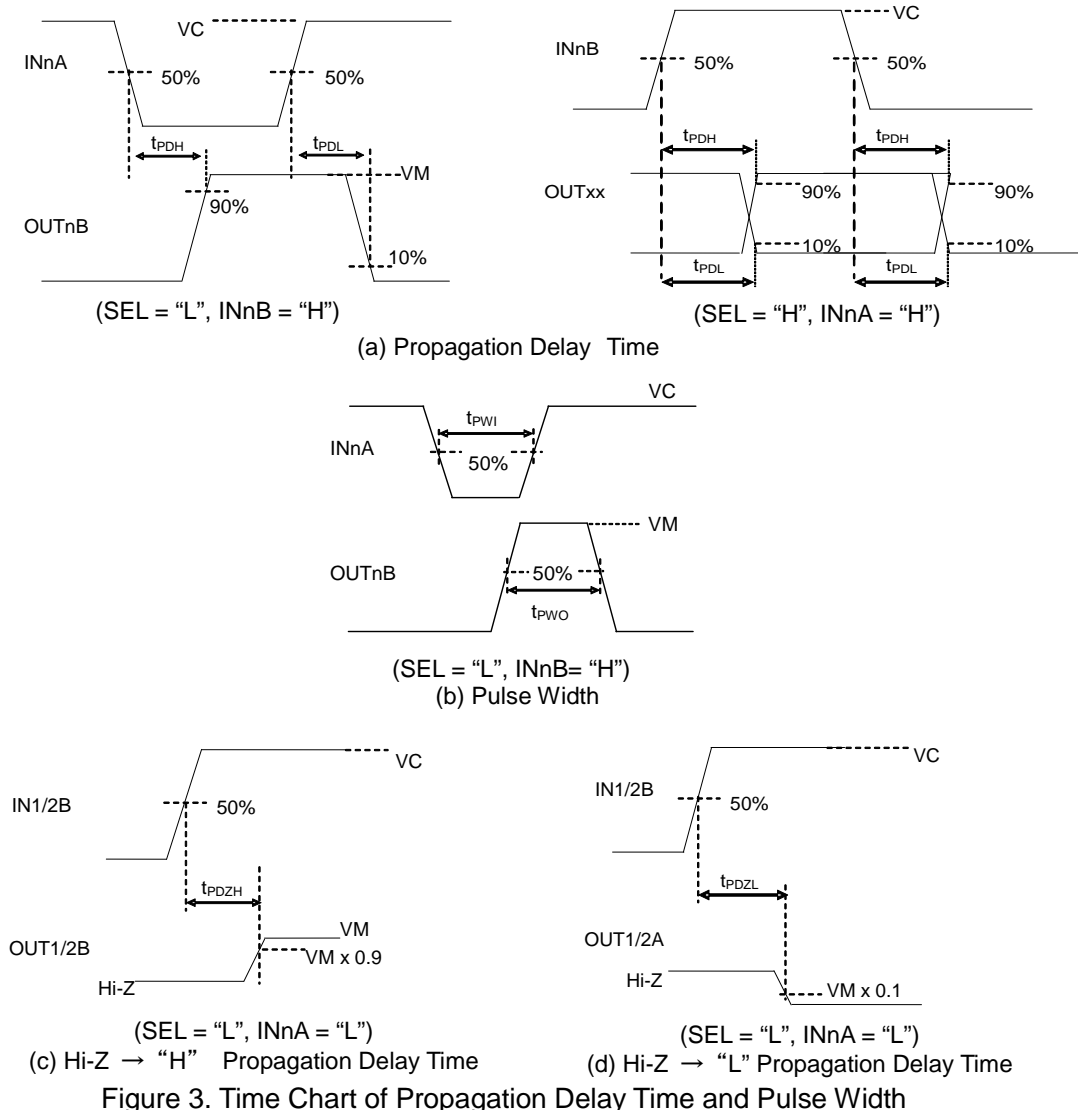

Figure 3. Time Chart of Propagation Delay Time and Pulse Width

9. Functional Descriptions

The AP1019 is a motor driver IC for stepping and voice coil motors. The output status (OUT1A, OUT1B, OUT2A, OUT2B) can be controlled by the input signals as shown in Table 1. The AP1019 has the under voltage detection and thermal shutdown functions. When the control power supply voltage (VC) becomes lower than the specified value, the H-Bridge driver outputs are set to Hi-Z by the under-voltage detection circuit (UVD). When abnormal internal high temperature is detected, the thermal shutdown function prevents damages from self-heating by setting OUTA and OUTB outputs Hi-Z.

9.1 Control Logic

The relations of the input and output with each mode are as follows.

Table 1. Output Status and Operation Mode according to Input Combinations

Input				Output		Motion
EN	SEL	INnA	INnB	OUTnA	OUTnB	
H	L	L	L	Z	Z	Standby (Idling)
		L	H	L	H	Reverse (CCW)
		H	L	H	L	Forward (CW)
		H	H	L	L	Brake (Stop)
	H	L	X	L	L	Brake (Stop)
		H	L	H	L	Forward (CW)
		H	H	L	H	Reverse (CCW)
L	X	X	X	Z	Z	Power off (Idling)

- EN Signal
Select Power ON/OFF status of the AP1019.
The AP1019 goes power-off state by setting the EN pin = "L". The output becomes OFF (Hi-Z) and the charge pump stops operation.
- SEL Signal
Select control logic
- INnA and INnB Signal
Control H-Bridge driver output status. H-Bridge statuses of each operation are shown in Figure 4.

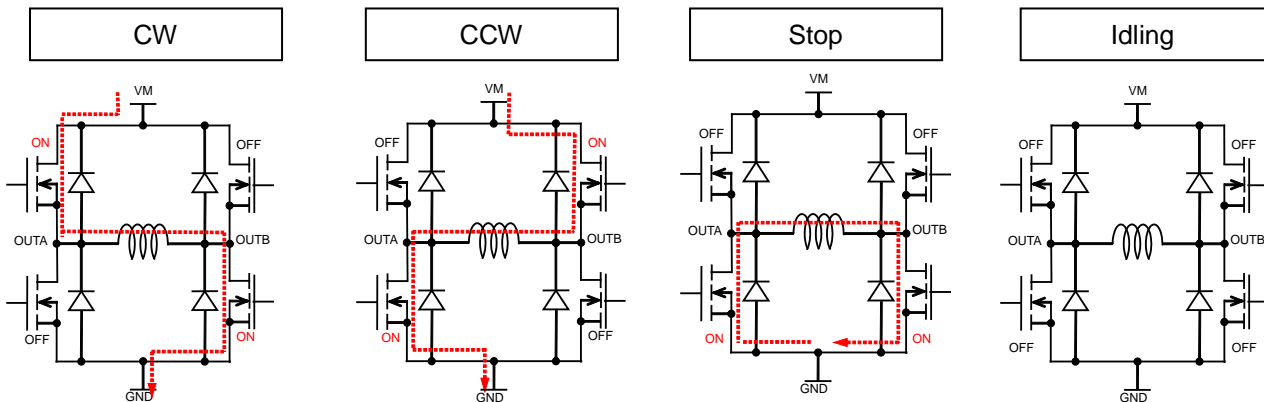

Figure 4. H-Bridge Driver Operation Status

9.2 Protection Functions

The AP1019 has shoot-through current prevention, thermal shutdown and under voltage detection circuits.

• **Shoot-through Current Prevention Circuit**

In order to prevent high side and low side MOSFETs from turning on at the same time, a through current prevention circuit is built in.

MOSFETs are turned off for both high side and low side during the dead time period that is when the shoot-through current prevention circuit is in operation. The dead time is included in the H-Bridge output delay time of the electrical characteristics. Figure 5 shows the signal timing images.

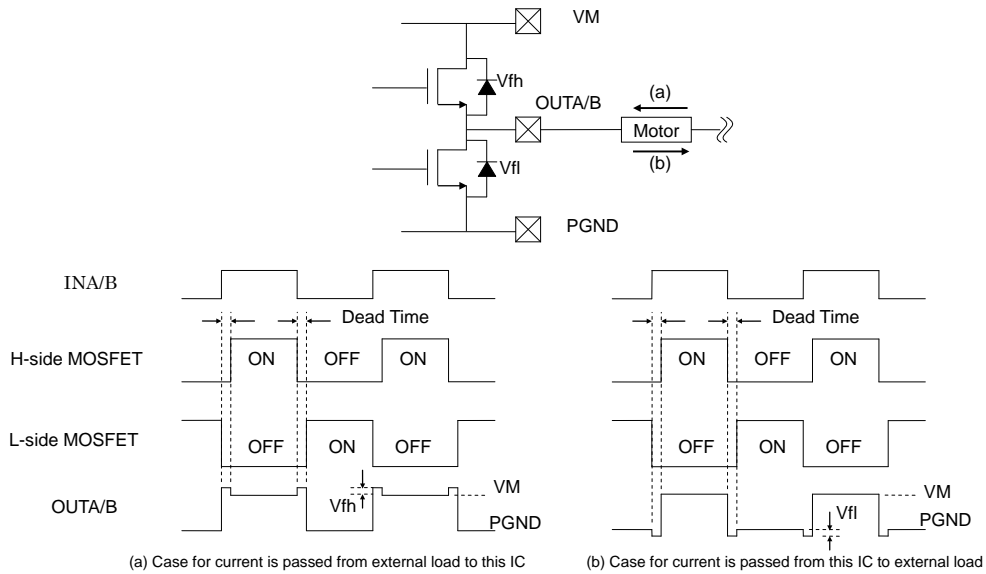

Figure 5. Difference In Output Terminal By Load Current Direction

• **Thermal Shut Down (TSD)**

The AP1019 prevents damages from self-heating by setting OUTA and OUTB outputs Hi-Z when abnormal high temperature is detected. The AP1019 is able to return to normal operation as soon as the temperature drops to the level lower than the bottom detection threshold.

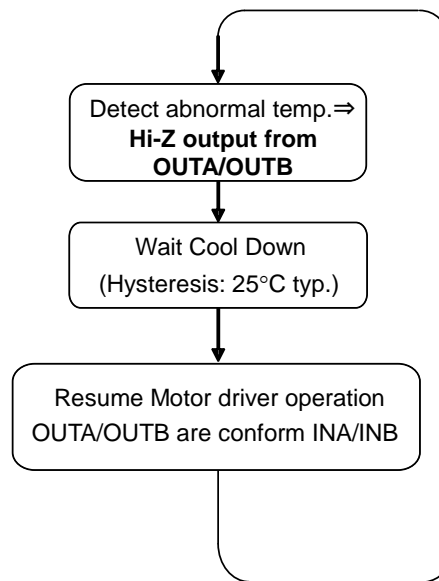

Figure 6. Detection of Abnormal Heat and Returning Normal Operation

• Under-voltage Detection Circuits (UVLO)

The H-Bridge driver outputs become high-impedance by the under-voltage detection circuit (UVD) when the control power supply voltage (VC) is lower than the specified value.

After the low-voltage detection, the H-Bridge driver will be operational when the control power supply voltage (VC) exceeds the value of specified voltage $VC_{UV} + \text{hysteresis voltage } VC_{UVHYS}$.

■ Timing Chart

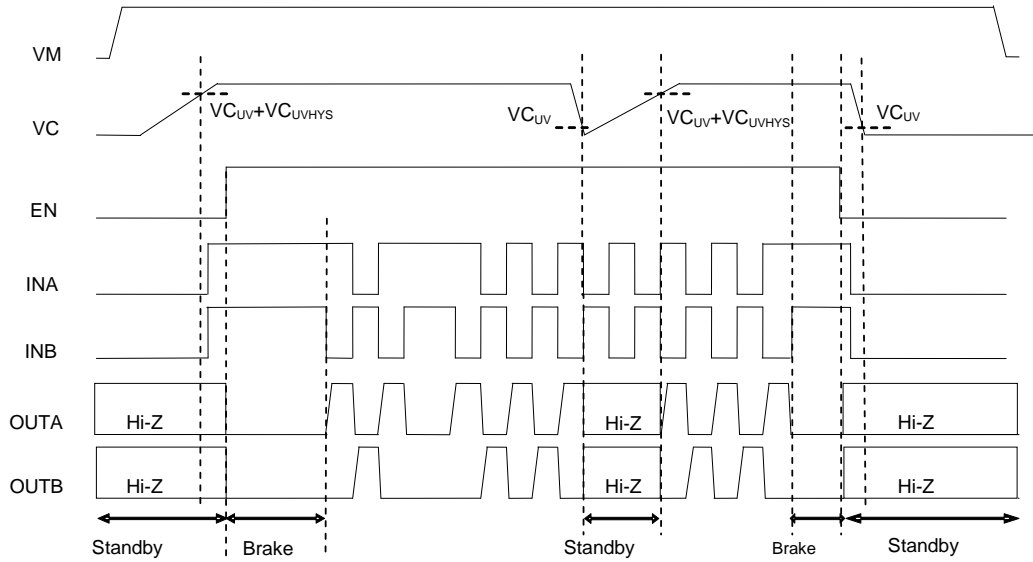

Figure 7. Timing Chart of Input and Output (In Case of Under Voltage Detection, SEL="L")

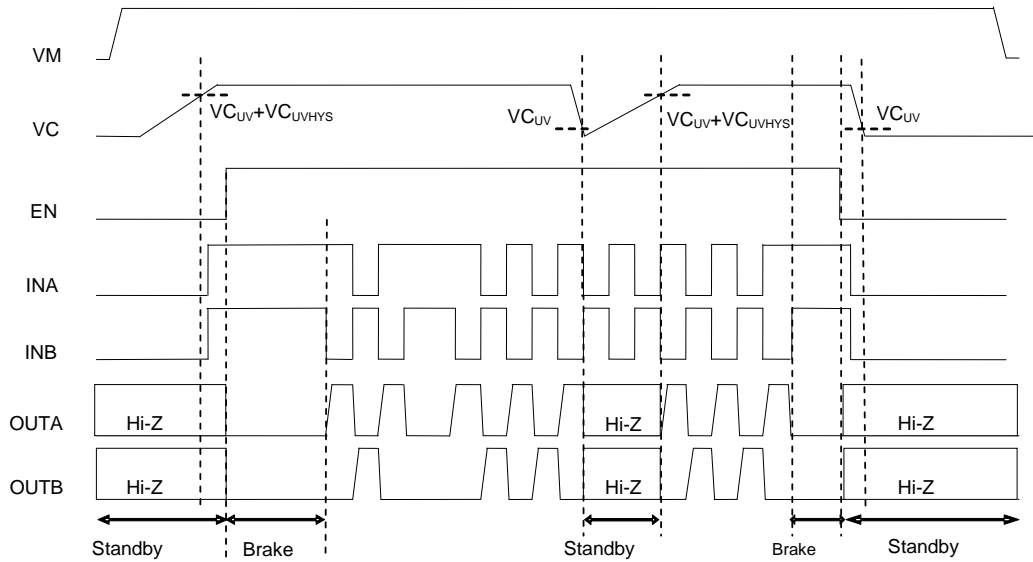

Figure 8. Timing Chart of Input and Output (In Case of TSD Detection, SEL="L")

9.3 Linearity Characteristic under PWM Control

AP1019 improves the switching speed between Forward and Reverse control from preceding products, and achieved the good linearity of output current against the PWM input with high frequency.

Condition : VC=3.0V, VM=5.0V, Room Temperature, 680 μ H + 20 Ω (7W), SEL="H"

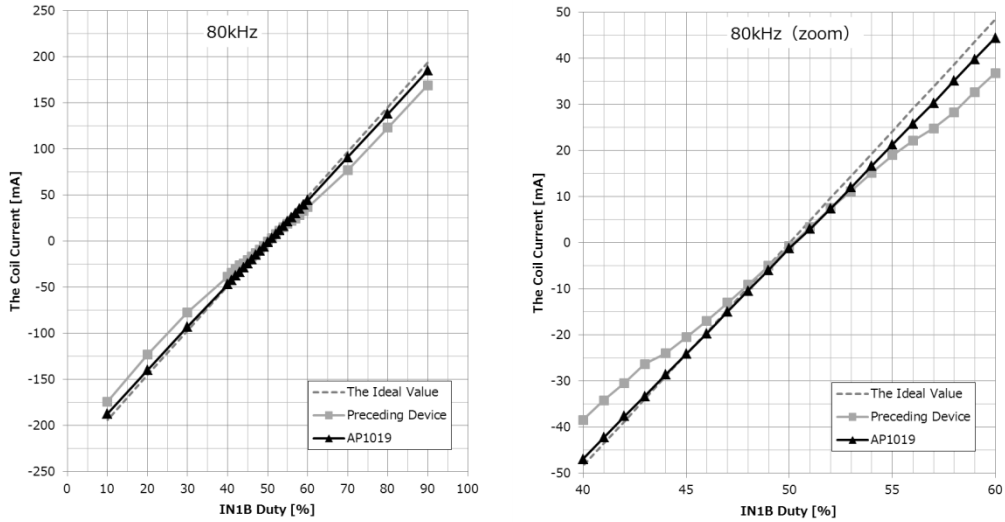

Figure 9. Linearity Characteristic (80kHz)

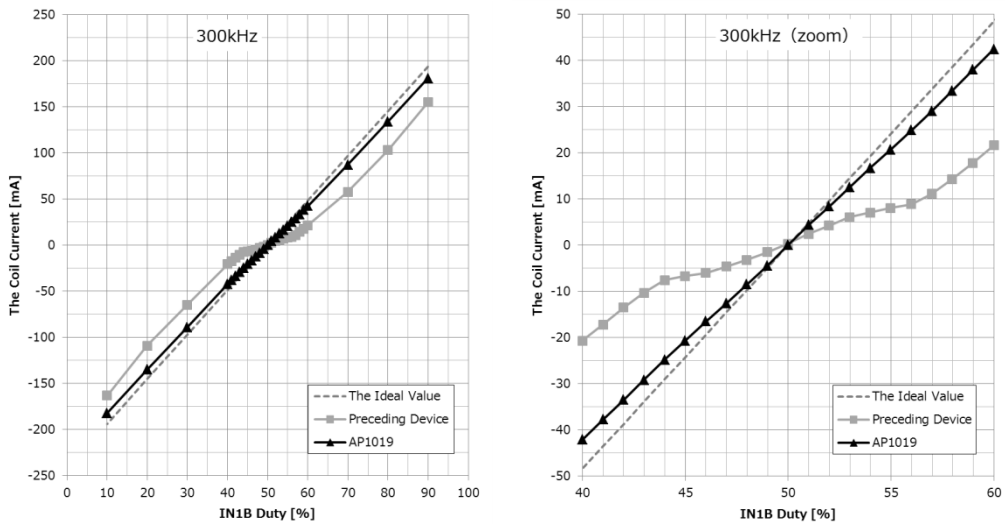

Figure 10. Linearity Characteristic (300kHz)

10. Recommended External Circuits

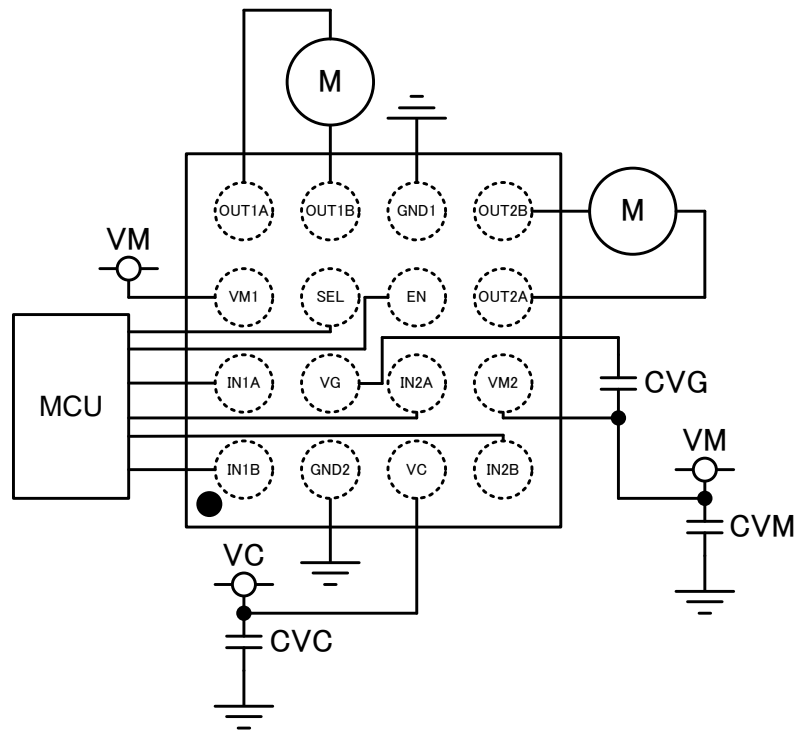

Figure 11. Recommended External Circuit

Table 2 Recommended External Components

Items	Symbol	Min.	Typ.	Max	Unit	Remarks
Motor Driver Power Supply (decoupling capacitor)	CVM	1.0	10	-	μF	(Note 8)
VC Control Power Supply (decoupling capacitor)	CVC	0.1	1.0	-	μF	
Charge Pump Capacitor 1	CVG	0.047	0.1	0.22	μF	

Note 8. Above values are examples. Please choose appropriate external components for your system board.

12. Ordering Guide

AP1019BEC -30~85°C 16-pin WLCSP (1.96mm×1.96mm)

13. Revision History

Date (Y/M/D)	Revision	Page	Contents
17/12/22	0.0		First Edition
19/02/15	0.1	1,6	<Spec Change> Recommended Operating Conditions Motor Driver Supply Voltage Min=2.0V -> 1.4V
		5	<Spec Change> Absolute Maximum Ratings Motor Supply Voltage 9.5V -> 10.0V VC+VM Level Terminal Voltage(VG) 15.5V -> 16.0V
		6	<Spec Change> Input Pulse Frequency Max=1000kHz -> FIN1 max=1000kHz (VM=2.0V~9.0V) FIN2 max=400kHz (VM=1.4V~2.0V)
		14	<Ordering Guide Change> AP1019AEC -> AP1019BEC

IMPORTANT NOTICE

0. Asahi Kasei Microdevices Corporation ("AKM") reserves the right to make changes to the information contained in this document without notice. When you consider any use or application of AKM product stipulated in this document ("Product"), please make inquiries the sales office of AKM or authorized distributors as to current status of the Products.
1. All information included in this document are provided only to illustrate the operation and application examples of AKM Products. AKM neither makes warranties or representations with respect to the accuracy or completeness of the information contained in this document nor grants any license to any intellectual property rights or any other rights of AKM or any third party with respect to the information in this document. You are fully responsible for use of such information contained in this document in your product design or applications. **AKM ASSUMES NO LIABILITY FOR ANY LOSSES INCURRED BY YOU OR THIRD PARTIES ARISING FROM THE USE OF SUCH INFORMATION IN YOUR PRODUCT DESIGN OR APPLICATIONS.**
2. The Product is neither intended nor warranted for use in equipment or systems that require extraordinarily high levels of quality and/or reliability and/or a malfunction or failure of which may cause loss of human life, bodily injury, serious property damage or serious public impact, including but not limited to, equipment used in nuclear facilities, equipment used in the aerospace industry, medical equipment, equipment used for automobiles, trains, ships and other transportation, traffic signaling equipment, equipment used to control combustions or explosions, safety devices, elevators and escalators, devices related to electric power, and equipment used in finance-related fields. Do not use Product for the above use unless specifically agreed by AKM in writing.
3. Though AKM works continually to improve the Product's quality and reliability, you are responsible for complying with safety standards and for providing adequate designs and safeguards for your hardware, software and systems which minimize risk and avoid situations in which a malfunction or failure of the Product could cause loss of human life, bodily injury or damage to property, including data loss or corruption.
4. Do not use or otherwise make available the Product or related technology or any information contained in this document for any military purposes, including without limitation, for the design, development, use, stockpiling or manufacturing of nuclear, chemical, or biological weapons or missile technology products (mass destruction weapons). When exporting the Products or related technology or any information contained in this document, you should comply with the applicable export control laws and regulations and follow the procedures required by such laws and regulations. The Products and related technology may not be used for or incorporated into any products or systems whose manufacture, use, or sale is prohibited under any applicable domestic or foreign laws or regulations.
5. Please contact AKM sales representative for details as to environmental matters such as the RoHS compatibility of the Product. Please use the Product in compliance with all applicable laws and regulations that regulate the inclusion or use of controlled substances, including without limitation, the EU RoHS Directive. AKM assumes no liability for damages or losses occurring as a result of noncompliance with applicable laws and regulations.
6. Resale of the Product with provisions different from the statement and/or technical features set forth in this document shall immediately void any warranty granted by AKM for the Product and shall not create or extend in any manner whatsoever, any liability of AKM.
7. This document may not be reproduced or duplicated, in any form, in whole or in part, without prior written consent of AKM.