



EM3242

Angle Sensor IC

Applications

- Small absolute rotary encoder
- Small input device (mode selector, volume control, and soon)
- Potentiometer
- Rotary switch

Features

- Si monolithic rotary position sensor IC with embedded Hall devices
- Contactless rotary position sensor is easily implemented with magnetic disc (radial magnetic) and sensor IC.
- Analog ratiometric output (10% VDD~90% VDD)
- 10 bit Angular Resolution
- 3V single power supply
- Extremely small temperature drift (typ. +/-1.0 degree)
- Ambient operating temperature range: Ta=-40 to 150°C
- Package: SOP6 body size 3.6×3.0×0.95mm

Block Diagram

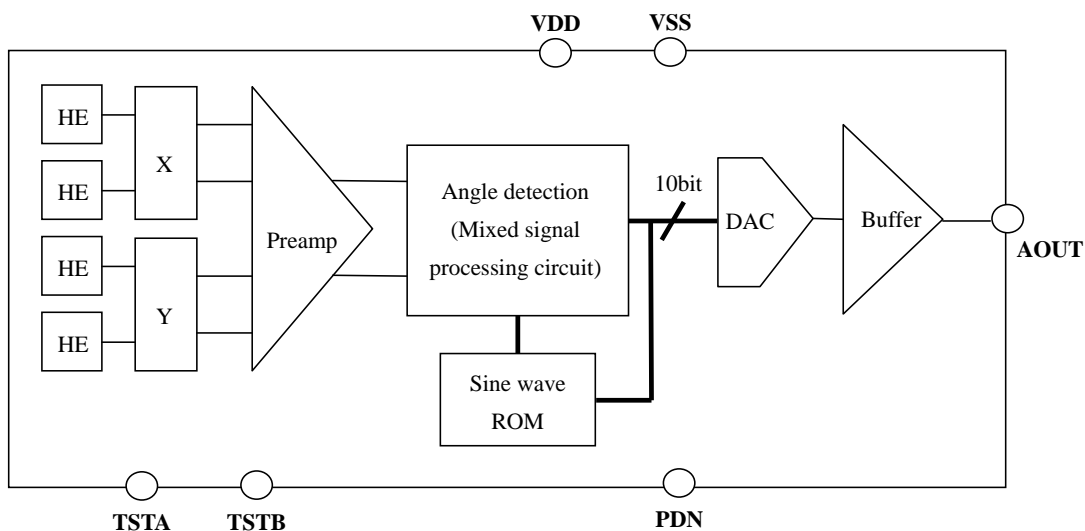

Functional Blocks

Block name	Function
HE	Hall Elements. These detect X/Y-compositions of flux which is parallel to the IC package surface by using magnetic concentrator.
PreAmp	This is able to amplify signals from Hall elements.
Angle Detection & Sine Wave ROM	Angle Detection makes digital angle data from signals from Hall Elements using Sine Wave ROM.
DAC	Digital to analog converter for angle output.

PIN Description

No.	Symbol	I/O	Type	Function
1	TSTB	I/O	Analog/Digital	TEST dedicated PIN, which should be connected to the GND in use.
2	VSS	-	Power	Ground PIN.
3	PDN	I	Analog	Power down PIN. IC is active in the case that PDN is High. IC is power down in the case that PDN is Low.
4	AOUT	O	Analog	Analog output PIN for angle data. CL: max.200pF (pull-down)
5	VDD	-	Power	Power Supply PIN. 0.1uF Ceramic Capacitor is required between Vss for stabilization. If Capacitor has magnetism, separate it around 10mm from IC.
6	TSTA	I/O	Analog	TEST dedicated PIN, which should be connected to the GND in use.

Application Circuit

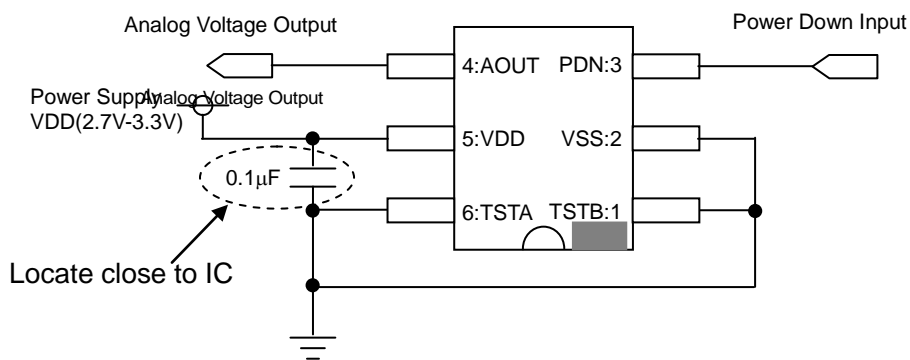

*Bypass capacitor must be inserted between VDD and VSS.

Absolute Maximum Ratings

Parameter	Symbol	Min.	Max.	Unit	備考
Supply Voltage	V _{DD}	-0.3	6.5	V	
Input Voltage	V _{IN}	-	V _{DD} +0.3	V	PDN terminal
Storage Temperature Range	T _{stg}	-50	+125	°C	

Operating Conditions

Parameter	Symbol	Min.	Typ.	Max.	Unit	Notes
Supply Voltage	V _{dd}	2.7	3.0	3.3	V	
Operating Temperature Range	T _a	-30	-	+85	°C	

Electrical & Magnetic Specifications

Condition is; T_a=25°C, V_{DD}=3.3V if particular notes are not defined.

Parameter	Symbol	Min.	Typ.	Max.	Unit	Notes
Magnetic Flux Density Range	B _{RANGE}	20	30	40	mT	@-30~85°C *2
Angle Detection Range	A _{RANGE}			360	Deg.	
Angle Resolution	A _{RES}		0.36		Deg.	10Bit
Angle error	A _{PREC}	-3.0		3.0	Deg.	@25°C *5 *8
Linearity	INL	-0.84		0.84	%FS	FS=360° *5
Angle temperature drift	A _{TD}		+/-1.0		Deg.	@-30~85°C (Reference)*1*6
Angle output cycle	T _p		40		μs	A/D Conversion Cycle *2
Signal delay time	T _d		140	180	μs	*2
Minimum Output Voltage	V _{OUT(min)}	0.095V _{DD}	0.1V _{DD}	0.105V _{DD}	V	@Angle 0° Ratiometric Load Condition *3
Maximum Output Voltage	V _{OUT(max)}	0.895V _{DD}	0.9V _{DD}	0.905V _{DD}	V	@Angle 359.64° Ratiometric Load Condition *4
Consumption Current While driving Sensor	I _{SUP}		8	12	mA	PDN:H *7
Consumption Current While Power Down	I _{PD}			1	μA	PDN:L *7
Startup time	T _{PD}		680	850	μs	PDN:L→H *2
Output Current	I _{OUT}	-0.3		0.3	mA	*2

*1) Based on Ambient Temperature = 25°C

*2) This is a design assurance parameter. And this parameter will not be inspected in mass production.

*3) AOUT Maximum Load Condition is CL=200pF (pull-down), AOUT Load Condition in Vout (min.) test: RL=9kΩ (pull-up), CL=200pF (pull-down)

*4) AOUT Maximum Load Condition is CL=200pF (pull-down), AOUT Load Condition in Vout (max.) test: RL=9kΩ (pull-down), CL=200pF (pull-down)

*5) Angle error

Angle Error is defined as below formula.

$$\text{Angle Error } [^\circ] = 360^\circ \times \text{Maximum Perpendicular Deviation} / (\text{Vout (max.)} - \text{Vout (min.)})$$

Linearity is defined as below formula.

$$\text{Linearity } [\% \text{FS.}] = \text{Maximum Perpendicular Deviation} / (\text{Vout (max.)} - \text{Vout (min.)}) \times 100 \quad [\% \text{FS.}]$$

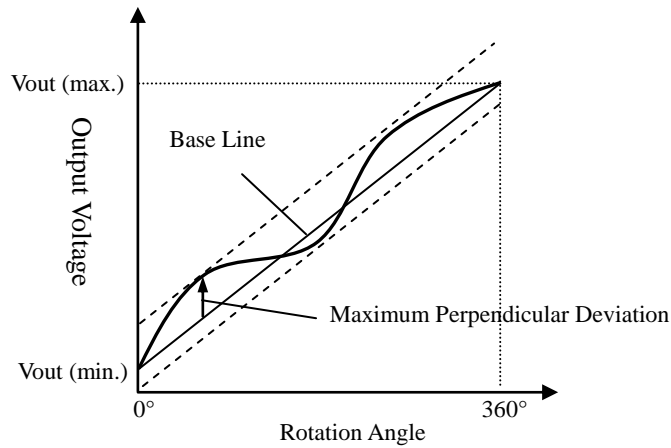

*6) Angle temperature drift

Vout temperature drift means temperature drift of output voltage at the same rotation angle.

Angle temperature drift is defined as below formula.

$$\text{Angle temperature drift } [^\circ] = 360^\circ \times \text{Vout temperature drift} / (\text{Vout (max.)} - \text{Vout (min.)})$$

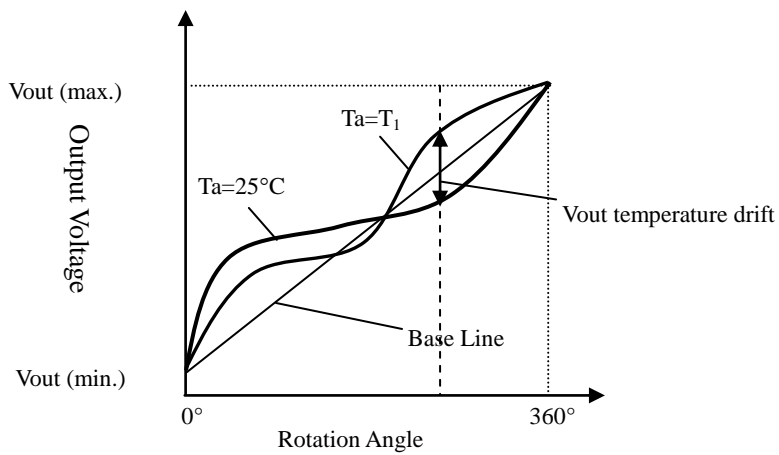

*7) No Load

*8) Reference (Angle Error)

<Measurement conditions>

1. Magnet: $\phi 7.0 \times t 2.0$ mm (Neodymium magnet: $B_r=1250$ mT)
2. Distance between the magnet and the package: Gap=4.0mm
(This Gap is the distance where the magnetic flux density at the sensor becomes 30mT)
3. Rotation angle of magnet: 0 to 360° (step: 1deg.)
4. Power Supply: $V_{dd}=3.3$ V
5. Bypass Capacitor: $C=0.1 \mu F$ (Distance from IC to Bypass Capacitor: $d=15$ mm)

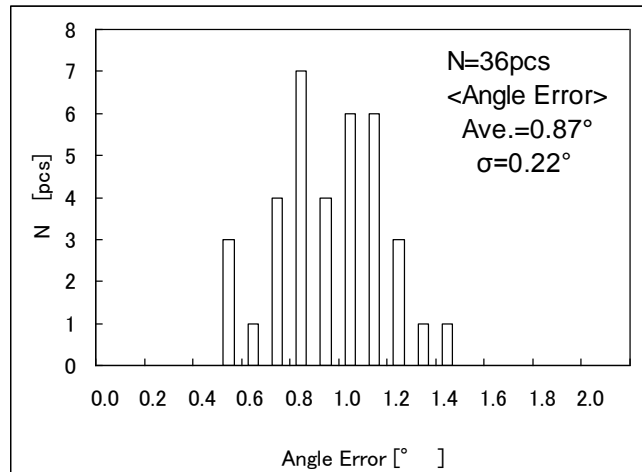

In this measurement conditions, Maximum of Angle Error (Ave.+5σ) is smaller than +/-2°

Startup time

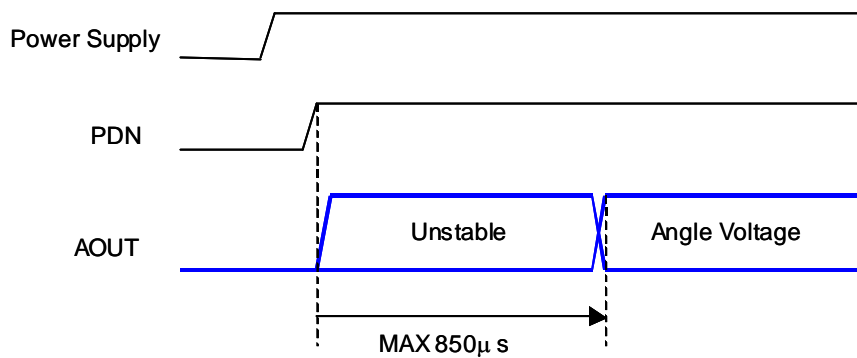

- 1) Please be noted that there is a certain period that the angle output voltage is unstable when EM-3242 goes to the operation from power down (PDN) mode, as shown above.
- 2) “Power Up Voltage” should be applied to PDN pin after applying “Power Supply Voltage” to VDD pin.

Magnet Direction and Output Voltage

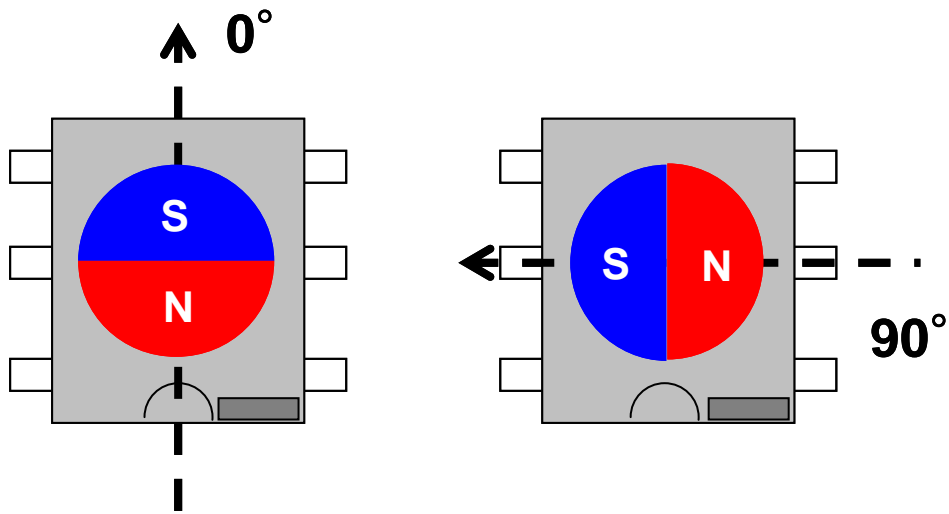

Marking side defines the N polar as 0°, the Output Voltage (AOUT) increases as the magnet rotates counterclockwise. In other words, it decreases as the magnet rotates clockwise.

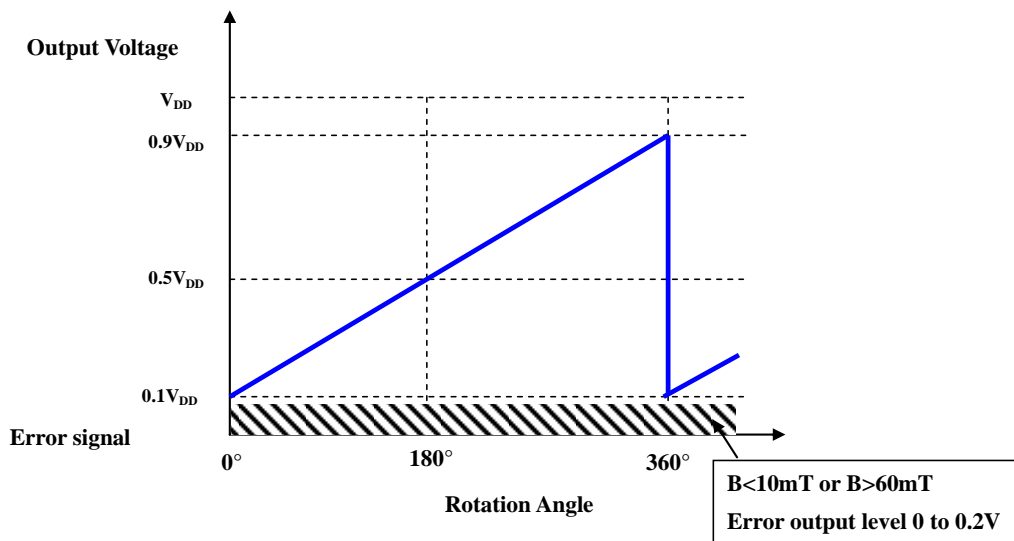

Package and Terminals

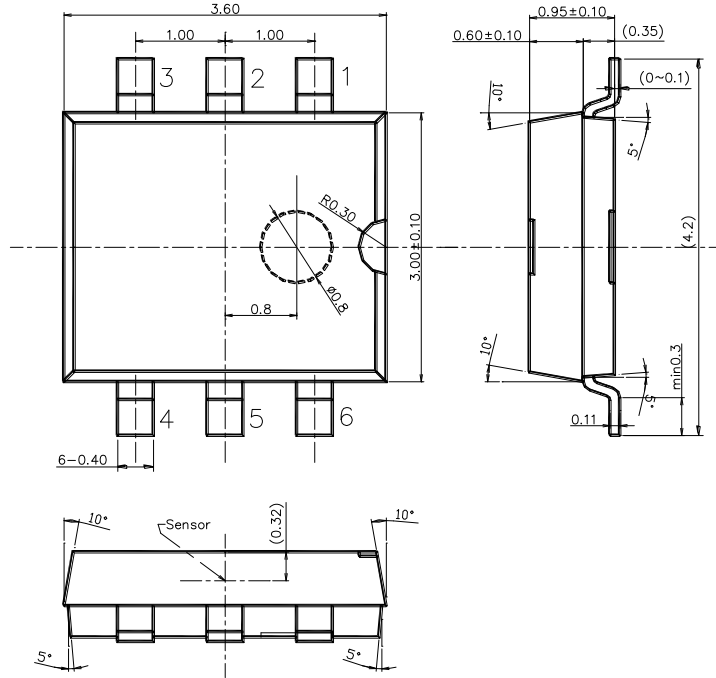

Material of the terminals; Cu
 Material of the plating; Sn
 Thickness of the plating; 10µm (Typ.)
 Weight; 24.3mg
 *This product is a Pb-Free Product.

IMPORTANT NOTICE

0. Asahi Kasei Microdevices Corporation (“AKM”) reserves the right to make changes to the information contained in this document without notice. When you consider any use or application of AKM product stipulated in this document (“Product”), please make inquiries the sales office of AKM or authorized distributors as to current status of the Products.
1. All information included in this document are provided only to illustrate the operation and application examples of AKM Products. AKM neither makes warranties or representations with respect to the accuracy or completeness of the information contained in this document nor grants any license to any intellectual property rights or any other rights of AKM or any third party with respect to the information in this document. You are fully responsible for use of such information contained in this document in your product design or applications. **AKM ASSUMES NO LIABILITY FOR ANY LOSSES INCURRED BY YOU OR THIRD PARTIES ARISING FROM THE USE OF SUCH INFORMATION IN YOUR PRODUCT DESIGN OR APPLICATIONS.**
2. The Product is neither intended nor warranted for use in equipment or systems that require extraordinarily high levels of quality and/or reliability and/or a malfunction or failure of which may cause loss of human life, bodily injury, serious property damage or serious public impact, including but not limited to, equipment used in nuclear facilities, equipment used in the aerospace industry, medical equipment, equipment used for automobiles, trains, ships and other transportation, traffic signaling equipment, equipment used to control combustions or explosions, safety devices, elevators and escalators, devices related to electric power, and equipment used in finance-related fields. Do not use Product for the above use unless specifically agreed by AKM in writing.
3. Though AKM works continually to improve the Product’s quality and reliability, you are responsible for complying with safety standards and for providing adequate designs and safeguards for your hardware, software and systems which minimize risk and avoid situations in which a malfunction or failure of the Product could cause loss of human life, bodily injury or damage to property, including data loss or corruption.
4. Do not use or otherwise make available the Product or related technology or any information contained in this document for any military purposes, including without limitation, for the design, development, use, stockpiling or manufacturing of nuclear, chemical, or biological weapons or missile technology products (mass destruction weapons). When exporting the Products or related technology or any information contained in this document, you should comply with the applicable export control laws and regulations and follow the procedures required by such laws and regulations. The Products and related technology may not be used for or incorporated into any products or systems whose manufacture, use, or sale is prohibited under any applicable domestic or foreign laws or regulations.
5. Please contact AKM sales representative for details as to environmental matters such as the RoHS compatibility of the Product. Please use the Product in compliance with all applicable laws and regulations that regulate the inclusion or use of controlled substances, including without limitation, the EU RoHS Directive. AKM assumes no liability for damages or losses occurring as a result of noncompliance with applicable laws and regulations.
6. Resale of the Product with provisions different from the statement and/or technical features set forth in this document shall immediately void any warranty granted by AKM for the Product and shall not create or extend in any manner whatsoever, any liability of AKM.
7. This document may not be reproduced or duplicated, in any form, in whole or in part, without prior written consent of AKM.